

**TEXTRON Lycoming**

652 Oliver Street  
Williamsport, PA 17701 U.S.A.  
717/323-6181

**MANDATORY**  
**SERVICE BULLETIN**

**DATE:** April 18, 1997

Service Bulletin No. 527C  
(Supersedes Service Bulletin No. 527B)  
Engineering Aspects are  
FAA Approved

**SUBJECT:** Recall of Piston Pin Part No. LW-14077

**MODELS AFFECTED:**

The following Textron Lycoming engine models could contain P/N LW-14077 piston pins:

O-320, (L)IO-320, AIO-320, AEIO-320.

(L)O-360, (L)IO-360, VO/IVO-360, HO-360, (L)HIO-360, AIO-360, AEIO-360, (L)TO/(L)TIO-360.

O-480, GO-480, IGO-480, GSO-480, IGSO-480.

O-540 (except O-540-J1A5D, -J1C5D, -J2A5D, -J3A5D, -J3C5D, -L3C5D), IO-540 (except IO-540-W1A5D, -W3A5D, -AB1A5), AEIO-540, (L)TIO-540, VO-540, IVO-540, TVO-540, TIVO-540, HIO-540, IGO-540, IGSO-540.

TIO-541, TIGO-541.

IO-720 Series aircraft engines.

Serial numbers of all engines affected and shipped from Textron Lycoming are listed as Attachment I for this bulletin.

Cylinder kits with P/N LW-14077 piston pins shipped from Textron Lycoming during the time period December 15, 1995 thru September 17, 1996 are listed as Attachment II for this bulletin.

Piston pins P/N LW-14077 shipped as spares during the time period December 15, 1995 thru September 17, 1996.

**NOTE**

Revision C of this Service Bulletin adds engine models which may contain piston pin P/N LW-14077. It is mandatory that the "Models Affected" section and Attachment I be reviewed for applicability to engines, including cylinder kits and spares. If an engine or cylinder kit was inspected per the requirements specified in Service Bulletin No. 527B, the requirements for compliance to Service Bulletin No. 527C have been met.

**TIME OF COMPLIANCE:** Prior to accumulation of 50 hours of operation with affected parts or within one year from the date of this Service Bulletin, whichever occurs first.  
Inventory of cylinder kits within thirty days.

Textron Lycoming has determined that a quantity of piston pins have been manufactured which do not meet Textron Lycoming manufacturing specifications. Some piston pins may have imperfections with no visual method of detection. The subject piston pins are identified by the code number located on the end of the pin as shown in Figure 1.

The following actions are required by this bulletin:

1. It is mandatory that all piston pins marked with code 17328 (per Figure 1) installed in engines manufactured and shipped from Textron Lycoming be removed from affected engines and returned to Textron Lycoming, Williamsport, PA. Subject engines are listed by models and serial numbers following the text of this bulletin. Satisfactory replacement pins are marked with codes BN or 71238 as shown in Figure 1.
2. Engines overhauled in the field using Piston Pin(s) P/N LW-14077 that were obtained during the time period December 15, 1995 thru September 17, 1996 must also have the piston pin(s) that are marked with code 17328 (per Figure 1) removed and returned to Textron Lycoming. Satisfactory replacement pins are marked with codes BN or 71238 as shown in Figure 1.
3. Any cylinder kits that were obtained/installed on engines during the time period December 15, 1995 thru September 17, 1996 that contain LW-14077 piston pins must have piston pin(s) that are marked with code 17328 (per Figure 1) removed and returned to Textron Lycoming. Satisfactory replacement pins are marked with codes BN or 71238 as shown in Figure 1.
  - a. If the cylinder kit has been installed on an engine, the cylinder assembly rocker cover flange must be inspected for a lot number which is permanent ink stamped on the flange (refer to Figure 2). The rocker cover must be removed to examine the lot number. Only the four or five digit number should be used for inspection. Any prefix letters should be ignored. Any five digit lot number and any cylinder marked with a four digit lot number less than 2450 requires the piston pin to be inspected for code marking as per Figure 1. If the four digit lot number is 2450 or greater, no further inspection is required.
  - b. Any cylinder kits which are still in kit form should be inspected for the date code which is stamped on top of the box. If the date code is between December 15, 1995 thru May 17, 1996 the piston pins should be inspected for the 17328 code and replaced. After this inspection the cylinder kit should be marked with permanent ink stating this cylinder kit complies with Service Bulletin No. 527C.
4. Any Piston Pin(s), LW-14077 obtained individually as spares during the time period December 15, 1995 thru September 17, 1996 that are marked with code 17328, must also be returned to Textron Lycoming, Williamsport, PA.

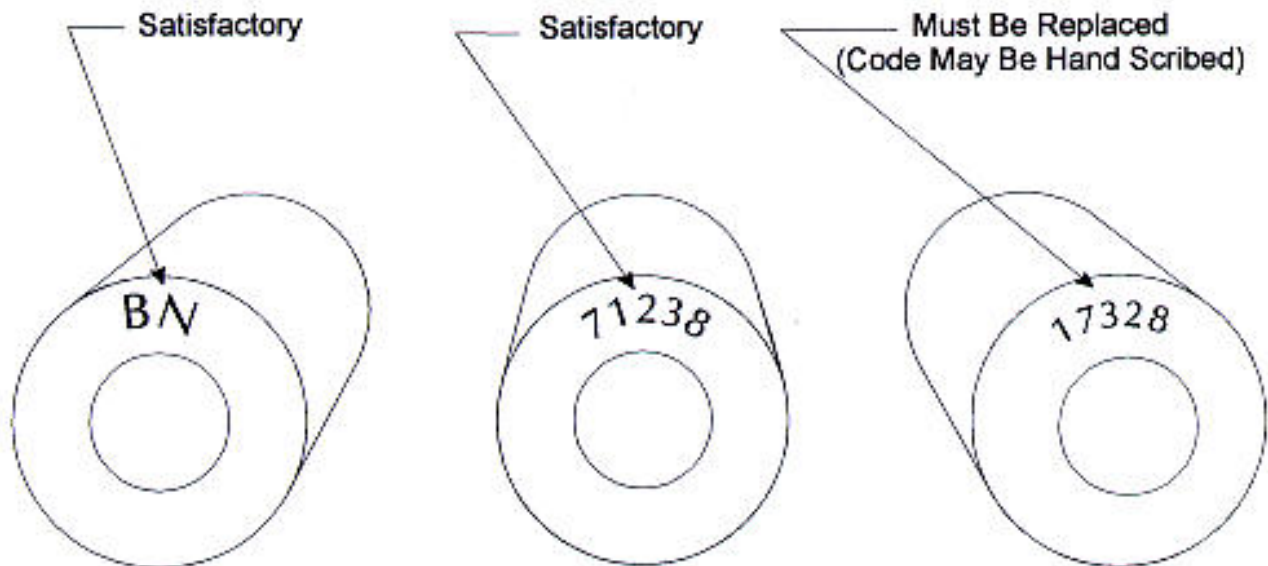
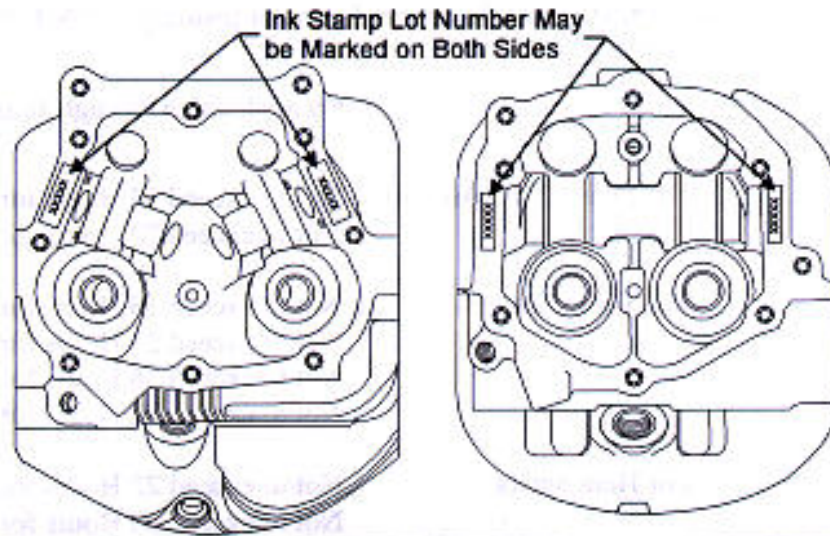
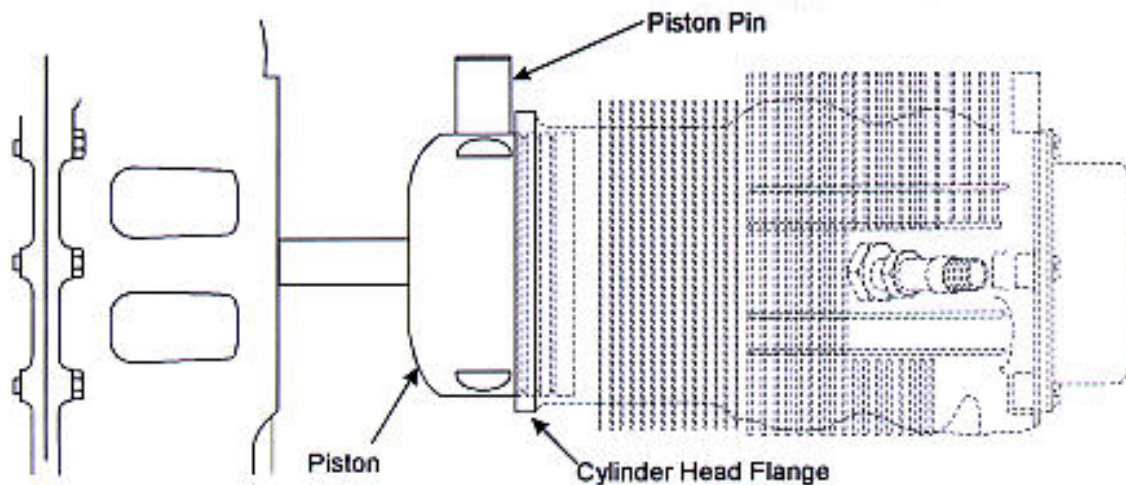

Figure 1.



**Figure 2.**



**NOTE**

**When removing cylinders for piston pin inspection, slide cylinder only far enough to allow removal of the pin without allowing rings to come out of cylinder as shown in Figure 3. It is not necessary to remove the piston from the cylinder for this inspection.**

**Figure 3.**

Engine models affected must have the piston pins inspected, and if needed, replacement pins reinstalled in accordance with the appropriate overhaul manual procedures and all applicable service literature.

After completion of this work, a logbook entry is required, stating that the engine has been inspected and complies with this Service Bulletin.

**WARRANTY:**

Cylinder Kit or Piston Pin P/N LW-14077 - It will be necessary to supply proof of purchase; copy of work order or purchase order to a Textron Lycoming Distributor for the issuance of credit.

**MATERIAL:** If required, by inspection, one (1) each replacement piston pin P/N LW-14077 per cylinder, through a Textron Lycoming Distributor.

**LABOR:** Labor costs can be recovered by submitting a warranty application through an authorized Textron Lycoming Distributor.

<b>Labor Allowances:</b>	For Fixed Wing Aircraft -	Not to exceed 13 Hours for 4 Cylinder Engines. Not to exceed 22 Hours for 6 Cylinder Engines
	For Turbocharged Aircraft	Not to exceed 16 Hours for 4 Cylinder Engines Not to exceed 26 Hours for 6 Cylinder Engines Not to exceed 36 Hours for TIO-540-AE2A Not to exceed 30 Hours for TIO-540-AF1A/B
	For Helicopters	Not to exceed 22 Hours for 4 Cylinder Engines Not to exceed 30 Hours for 6 Cylinder Engines

Labor and material allowances will be effective until one (1) year from date of this Bulletin.

Replacement pins should be ordered through your authorized Textron Lycoming Distributor. Return subject piston pins through normal warranty procedure.

**ATTACHMENT I - Service Bulletin No. 527C**

**NEW ENGINES:**

O-320-B2B - L-18437-39A, L-18441-39A, L-18446-39A.  
O-320-D1A - L-18438-39A, L-18439-39A, L-18440-39A, L-18443-39A, L-18444-39A, L-18445-39A, L-18448-39A, L-18453-39A, L-18454-39A, L-18465-39A, L-18471-39A, L-18475-39A, L-18481-39A, L-18482-39A, L-18483-39A.  
O-320-D1F - L-18447-39A, L-18474-39A, L-18477-39A.  
O-320-D2A - L-18449-39A, L-18450-39A, L-18451-39A, L-18452-39A, L-18455-39A, L-18456-39A, L-18457-39A, L-18458-39A, L-18459-39A, L-18460-39A, L-18461-39A, L-18462-39A, L-18463-39A, L-18464-39A, L-18466-39A, L-18468-39A, L-18469-39A, L-18470-39A, L-18472-39A.  
O-320-D3G - L-18476-39A, L-18480-39A.  
O-320-E2A - L-50590-27A, L-50591-27A.  
IO-320-D1B - L-5982-55A.  
O-360-A1A - L-34859-36A, L-34861-36A, L-34862-36A, L-34863-36A, L-34879-36A, L-34881-36A, L-34882-36A, L-34888-36A, L-34917-36A, L-34918-36A, L-34919-36A, L-34921-36A, L-34926-36A, L-34947-36A, L-34948-36A, L-34950-36A, L-34990-36A, L-34991-36A, L-35011-36A.  
O-360-A1AD - L-34858-36A, L-34872-36A, L-34873-36A, L-34874-36A, L-34898-36A, L-34899-36A, L-34901-36A.  
O-360-A1F6 - L-34850-36A, L-34851-36A, L-34852-36A.  
O-360-A1F6D - L-34971-36A.  
O-360-A1H6 - L-34886-36A, L-34943-36A.  
O-360-A1P - L-34842-36A, L-34870-36A, L-34871-36A, L-34889-36A, L-34897-36A, L-34920-36A, L-34946-36A, L-34949-36A, L-34956-36A, L-34966-36A, L-34987-36A.  
O-360-A3A - L-34843-36A, L-34884-36A, L-34885-36A.  
O-360-A4H - L-34518-36A.  
O-360-A4M - L-34833-36A, L-34848-36A, L-34849-36A, L-34854-36A, L-34855-36A, L-34860-36A, L-34876-36A, L-34877-37A, L-34880-36A, L-34905-36A, L-34906-36A, L-34916-36A, L-34922-36A, L-34925-36A, L-34934-36A, L-34937-36A, L-34938-36A, L-34939-36A, L-34940-36A, L-34945-36A, L-34955-36A, L-34959-36A, L-34960-36A, L-34962-36A, L-34965-36A, L-34968-36A, L-34969-36A, L-34970-36A, L-34976-36A, L-34977-36A, L-34978-36A, L-34979-36A, L-34981-36A, L-34982-36A, L-34983-36A, L-34984-36A, L-34988-36A, L-34989-36A, L-34994-36A.  
O-360-C1F - L-34864-36A, L-34867-36A, L-34902-36A, L-34903-36A, L-34929-36A, L-34930-36A, L-34931-36A, L-34932-36A.  
O-360-C1G - L-34895-36A, L-34896-36A, L-34911-36A, L-34912-36A.  
O-360-J2A - L-34844-36A, L-34845-36A, L-34846-36A, L-34847-36A, L-34893-36A, L-34894-36A, L-34900-36A, L-34904-36A, L-34907-36A, L-34913-36A, L-34914-36A, L-34915-36A, L-34927-36A, L-34928-36A, L-34935-36A, L-34936-36A, L-34944-36A, L-34953-36A, L-34954-36A, L-34957-36A, L-34958-36A, L-34963-36A, L-34964-36A, L-34974-36A, L-34999-36A, L-35001-36A, L-35002-36A, L-35003-36A.  
IO-360-A1B6 - L-26793-51A, L-26794-51A, L-26795-51A, L-26800-51A, L-26801-51A, L-26805-51A, L-26814-51A, L-26815-51A, L-26816-51A.  
IO-360-A3B6 - L-26780-51A, L-26796-51A, L-26797-51A, L-26802-51A, L-26806-51A, L-26807-51A, L-26808-51A, L-26820-51A, L-26827-51A, L-26837-51A.  
IO-360-A3B6D - L-26809-51A.  
IO-360-B1E - L-26829-51A, L-26838-51A, L-26840-51A.  
IO-360-B1F - L-26778-51A, L-26779-51A, L-26823-51A.  
IO-360-C1C6 - L-26791-51A, L-26803-51A, L-26813-51A.  
IO-360-C1E6 - L-26776-51A, L-26777-51A, L-26787-51A, L-26834-51A.  
IO-360-X128 - L-26858-51A.  
IO-360-X129 - L-1308-00X, L-1309-00X.  
HIO-360-D1A - L-26790-51A, L-26798-51A, L-26799-51A, L-26810-51A, L-26812-51A, L-26818-51A, L-26819-51A, L-26821-51A, L-26822-51A, L-26828-51A, L-26836-51A.  
HIO-360-F1AD - L-26775-51A.  
HO-360-C1A - L-34865-36A, L-34866-36A, L-34868-36A, L-34869-36A, L-34883-36A, L-34890-36A, L-34891-36A, L-34892-36A, L-34908-36A, L-34909-36A, L-34910-36A, L-34933-36A, L-34942-36A, L-34951-36A, L-34952-36A, L-34961-36A, L-34986-36A, L-34993-36A.  
IVO-360-A1A - L-265-58A, L-266-58A, L-267-58A, L-268-58A, L-269-58A.  
LO-360-A1H6 - L-586-71A, L-587-71A.  
AEIO-360-A1E - L-26842-51A.  
AEIO-360-B2F - L-26811-51A, L-26826-51A.  
AEIO-360-H1B - L-26788-51A, L-26789-51A, L-26817-51A, L-26830-51A, L-26831-51A, L-26832-51A.  
AEIO-360-A1B6 - L-26783-51A, L-26784-51A, L-26824-51A, L-26825-51A.  
AEIO-360-A1E6 - L-26804-51A.  
O-540-B4B5 - L-24960-40A.  
O-540-E4A5 - L-24954-40A, L-24955-40A, L-24956-40A, L-24957-40A, L-24959-40A.

**NEW ENGINES (Continued):**

O-540-E4C5 - L-24946-40A, L-24947-40A.  
O-540-F1B5 - L-24948-40A, L-24949-40A, L-24950-40A, L-24951-40A, L-24952-40A, L-24953-40A, L-24958-40A, L-24961-40A, L-24962-40A, L-24963-40A, L-24964-40A, L-24965-40A, L-24966-40A, L-24967-40A, L-24968-40A, L-24969-40A, L-24971-40A, L-24972-40A, L-24974-40A, L-24975-40A, L-24976-40A, L-24977-40A, L-24978-40A, L-24979-40A, L-24980-40A, L-24981-40A.  
O-540-J3A5 - L-24944-40A, L-24945-40A, L-24970-40A, L-24973-40A.  
IO-540-C4D5D - L-25763-48A, L-25764-48A, L-25765-48A, L-25783-48A, L-25784-48A, L-25790-48A, L-25791-48A, L-25801-48A, L-25802-48A.  
IO-540-K1B5 - L-25774-48A, L-25807-48A, L-25815-48A.  
IO-540-K1G5 - L-25754-48A, L-25758-48A, L-25762-48A, L-25766-48A, L-25767-48A, L-25768-48A, L-25781-48A, L-25782-48A, L-25785-48A, L-25786-48A, L-25789-48A, L-25792-48A, L-25793-48A, L-25795-48A, L-25803-48A, L-25804-48A, L-25813-48A, L-25818-48A.  
IO-540-T4B5 - L-25799-48A.  
TIO-540-ABIAD - L-9703-61A, L-9707-61A, L-9724-61A.  
TIO-540-AE2A - L-9674-61A, L-9685-61A, L-9687-61A, L-9688-61A, L-9689-61A, L-9690-61A, L-9691-61A, L-9692-61A, L-9693-61A, L-9700-61A, L-9702-61A, L-9704-61A, L-9706-61A, L-9712-61A, L-9713-61A, L-9714-61A, L-9715-61A, L-9717-61A, L-9719-61A.  
TIO-540-AF1B - L-9695-61A, L-9697-61A, L-9698-61A, L-9699-61A.  
TIO-540-AG1A - L-9627-61A, L-9672-61A.  
TIO-540-J2B - L-9708-61A.  
TIO-540-U2A - L-9722-61A.  
TIO-540-W2A - L-9705-61A.  
LTIO-540-J2B - L-2952-68A.  
AEIO-540-D4A5 - L-25759-48A, L-25761-48A, L-25772-48A, L-25775-48A, L-25777-48A, L-25778-48A, L-25788-48A, L-25794-48A, L-25798-48A, L-25800-48A, L-25805-48A, L-25808-48A, L-25809-48A, L-25810-48A, L-25811-48A, L-25812-48A, L-25819-48A.  
AEIO-540-L1B5 - L-25755-48A, L-25756-48A, L-25769-48A, L-25770-48A, L-25776-48A, L-25779-48A, L-25780-48A, L-25787-48A, L-25796-48A, L-25797-48A, L-25806-48A.

**OVERHAULED AND REMANUFACTURED ENGINES:**

O-320-A2B - L-19727-27A, L-21482-27A, L-25373-27A, L-29468-27A, L-32493-27A, L-32725-27A, L-33989-27A, L-35896-27A, L-39669-27A, L-39817-27A, L-40694-27A, L-40876-27A, L-41559-27A, L-42408-27A, L-44990-27A, RL-19533-27A, RL-25674-27A, RL-40178-27A, RL-44023-27A.  
O-320-A2C - L-15464-27A.  
O-320-A3A - L-44752-27A.  
O-320-A3C - L-24900-27A.  
O-320-B2B - L-7107-39A, L-12182-39A, L-13030-39A, L-15849-39A, RL-10234-39A, RL-18467-39A.  
O-320-B2C - L-5710-39A, L-10232-39A, L-11214-39A, L-11351-39A, L-11517-39A, L-12105-39A, L-12301-39A, L-13167-39A, L-13396-39A, L-13480-39A, L-13587-39A, L-13614-39A, L-13971-39A, L-13973-39A, L-14030-39A, L-14161-39A, L-14344-39A, L-14375-39A, L-14378-39A, L-14381-39A, L-14399-39A, L-14407-39A, L-14456-39A, L-14494-39A, L-14527-39A, L-14569-39A, L-14741-39A, L-14929-39A, L-14996-39A, L-15025-39A, L-15249-39A, L-15701-39A, L-15789-39A, L-15803-39A, L-15808-39A, L-15813-39A, L-15931-39A, L-15950-39A, L-15954-39A, L-16096-39A, L-16097-39A, L-16135-39A, L-16315-39A, L-16327-39A, L-16425-39A, L-16523-39A, L-16539-39A, L-16554-39A, L-16563-39A, L-16682-39A, L-16877-39A, L-16893-39A, L-16901-39A, L-16906-39A, L-16927-39A, L-16968-39A, L-17039-39A, L-17163-39A, L-17178-39A, L-17194-39A, L-17278-39A, L-17457-39A, L-17463-39A, L-17733-39A, L-17974-39A.  
O-320-D1A - RL-8499-39A.  
O-320-D1D - L-15524-39A, RL-12564-39A.  
O-320-D2A - L-1524-39A, L-2275-39A, L-6339-39A, L-6980-39A, L-8836-39A, L-10261-39A, L-10681-39A, L-10907-39A, L-11265-39A, L-12570-39A, L-13004-39A, L-14270-39A, L-14882-39A, L-15075-39A, L-17565-39A, RL-9736-39A, RL-10675-39A, RL-10874-39A, RL-11996-39A, RL-18473-39A.  
O-320-D2B - L-9170-39A.  
O-320-D2G - L-9779-39A, L-10227-39A, RL-17474-39A.

**ATTACHMENT I - Service Bulletin No. 527C**

**OVERHAULED AND REMANUFACTURED ENGINES (Continued)**

**O-320-D2J** - L-577-39A, L-1468-39A, L-5132-39A, L-5591-39A, L-6462-39A, L-6803-39A, L-6965-39A, L-7071-39A, L-7326-39A, L-7340-39A, L-7581-39A, L-8166-39A, L-8745-39A, L-8755-39A, L-9100-39A, L-9228-39A, L-9345-39A, L-9650-39A, L-9830-39A, L-10073-39A, L-10901-39A, L-10917-39A, L-11175-39A, L-11626-39A, L-12003-39A, L-12009-39A, L-12077-39A, L-12396-39A, L-12720-39A, L-12905-39A, L-12908-39A, L-13342-39A, L-13828-39A, L-14036-39A, L-14212-39A, L-14547-39A, L-14704-39A, L-14755-39A, L-15379-39A, L-15447-39A, L-15586-39A, L-15602-39A, L-17305-39A, RL-7048-39A, RL-7267-39A, RL-7650-39A, RL-8043-39A, RL-8892-39A, RL-9014-39A, RL-9107-39A, RL-9433-39A, RL-10538-39A, RL-11873-39A, RL-12447-39A, RL-13160-39A, RL-13260-39A, RL-13819-39A, RL-14787-39A, RL-15185-39A, RL-18442-39A.

**O-320-D3G** - L-7075-39A, L-7749-39A, L-8189-39A, L-8661-39A, L-8993-39A, L-9359-39A, L-9619-39A, L-10004-39A, L-10126-39A, L-10217-39A, L-10497-39A, L-10765-39A, L-10787-39A, L-10905-39A, L-11120-39A, L-11908-39A, L-11975-39A, L-12393-39A, L-12555-39A, L-12602-39A, L-12888-39A, L-12996-39A, L-13198-39A, L-13447-39A, L-13493-39A, L-13599-39A, L-13719-39A, L-14078-39A, L-14081-39A, L-14312-39A, L-14447-39A, L-14734-39A, L-14816-39A, L-15362-39A, L-15397-39A, L-15431-39A, L-15487-39A, L-15534-39A, L-15600-39A, L-16120-39A, L-16299-39A, L-16631-39A, L-16694-39A, L-16932-39A, L-17020-39A, RL-7901-39A, RL-7972-39A, RL-9585-39A, RL-10485-39A, RL-10759-39A, RL-10761-39A, RL-11334-39A, RL-11480-39A, RL-12159-39A, RL-12675-39A, RL-13075-39A, RL-13196-39A, RL-13598-39A, RL-14624-39A, RL-15344-39A, RL-15747-39A.

**O-320-E2A** - L-15671-27A, L-19451-27A, L-24467-27A, L-25749-27A, L-29779-27A, L-37568-27A, L-38786-27A, L-39910-27A, L-44453-27A, L-44544-27A.

**O-320-E2C** - L-17019-27A.

**O-320-E2D** - L-15787-27A, L-19056-27A, L-19167-27A, L-22839-27A, L-24611-27A, L-25210-27A, L-26518-27A, L-29142-27A, L-29642-27A, L-29951-27A, L-31004-27A, L-31790-27A, L-32206-27A, L-32327-27A, L-33034-27A, L-33043-27A, L-33305-27A, L-33359-27A, L-34028-27A, L-34817-27A, L-36244-27A, L-37172-27A, L-39009-27A, L-39045-27A, L-39513-27A, L-39696-37A, L-41169-27A, L-41292-27A, L-41880-27A, L-43052-27A, L-43133-27A, L-43780-27A, L-44133-27A, L-44325-27A, L-44359-27A, L-44467-27A, L-44530-27A, L-44533-27A, L-44545-27A, L-44549-27A, L-44562-27A, L-44606-27A, L-44712-27A, L-44745-27A, L-44787-27A, L-44899-27A, L-44916-27A, L-44945-27A, L-44953-27A, L-44961-27A, RL-17385-27A, RL-19856-27A, RL-28241-27A, RL-30156-27A, RL-42588-27A, RL-43652-27A, RL-48803-27A.

**O-320-E2G** - L-32514-27A, L-37115-27A, L-44853-27A, L-48632-27A.

**O-320-E3D** - L-15236-27A, L-16333-27A, L-19198-27A, L-20311-27A, L-22235-27A, L-25852-27A, L-25877-27A, L-29263-27A, L-32613-27A, L-33136-27A, L-33647-27A, L-34669-27A, L-36069-27A, L-36885-27A, L-44340-27A, L-44956-27A, L-50420-27A, RL-25341-27A, RL-46393-27A, RL-50467-27A.

**O-320-H2AD** - L-572-76T, L-578-76T, L-1193-76T, L-1322-76T, L-2025-76T, L-2584-76T, L-2657-76T, L-2818-76T, L-2939-76T, L-3032-76T, L-3090-76T, L-3226-76T, L-3292-76T, L-3368-76T, L-3619-76T, L-3823-76T, L-3838-76T, L-3888-76T, L-4157-76T, L-4346-76T, L-4487-76T, L-4494-76T, L-4507-76T, L-4515-76T, L-4580-76T, L-4663-76T, L-4848-76T, L-4937-76T, L-5036-76T, L-5064-76T, L-5080-76T, L-5104-76T, L-5465-76T, L-5692-76T, L-5782-76T, L-5827-76T, L-5988-76T, L-6028-76T, L-6032-76T, L-6715-76T, L-6823-76T, L-6952-76T, L-7108-76T, L-7711-76T, L-8071-76T, L-8141-76T, L-8203-76T, L-8305-76T, L-8314-76T, RL-347-76T, RL-1112-76T, RL-1584-76T, RL-2208-76T, RL-2303-76T, RL-2309-76T, RL-2758-76T, RL-3608-76T, RL-3614-76T, RL-3904-76T, RL-4344-76T, RL-4831-76T, RL-4857-76T, RL-5151-76T, RL-6288-76T, RL-7393-76T, RL-7808-76T, RL-8270-76T.

**IO-320-B1A** - L-965-55A, L-974-55A, L-1020-55A, L-2745-55A, L-5289-55A, L-5523-55A, L-5797-55A, RL-3412-55A.

**IO-320-C1A** - L-3574-55A.

**IO-320-D1B** - L-858-55A.

**LIO-320-B1A** - L-234-66A, L-307-66A.

**AEIO-320-D1B** - L-1021-55A, L-3607-55A.

**AEIO-320-E1B** - RL-2650-55A.

**AEIO-320-E2B** - L-5905-55A.

**O-360-A1A** - L-3799-36A, L-12612-36A, L-19822-36A, L-27271-36A, L-27981-36A, L-29286-36A, L-29920-36A, L-30369-36A, L-31985-36A, RL-34924-36A.

**O-360-A1AD** - L-15546-36A, L-15855-36A, L-18862-36A, L-30763-36A, RL-34923-36A.

**O-360-A1D** - L-6134-36, L-7323-36A, L-8158-36A, L-8864-36A, L-11553-36A, L-12822-36A, L-23635-36A, L-24717-36A, L-25608-36A, L-26576-36A, L-29094-36A, L-29275-36A, L-32350-36A, L-33189-36A.

**O-360-A1F6** - L-23853-36A, L-26878-36A, RL-34995-36A.

**O-360-A1F6D** - L-18021-36A, L-18285-36A, L-20697-36A, L-21675-36A, L-22170-36A, RL-19718-36A, RL-27679-36A.

**O-360-A1G6D** - L-6644-36A, L-9481-36A, L-23276-36A, L-27673-36A, L-30821-36A, L-31066-36A, L-32309-36A, RL-17491-36A, RL-22469-36A.

**O-360-A2A** - L-9494-36A.

**O-360-A2F** - RL-7804-36A.

**OVERHAULED AND REMANUFACTURED ENGINES (Continued):**

**O-360-A3A** - L-7831-36A, L-11909-36A, L-14833-36A, L-15283-36A, L-17397-36A, L-18445-36A, L-19783-36A, L-21331-36A, L-23342-36A, L-23555-36A, L-24129-36A, L-24159-36A, L-24423-36A, L-25745-36A, L-27270-36A, L-2788-36A, L-28236-36A, L-28571-36A, L-28923-36A, L-29137-36A, L-30774-36A, L-31347-36A, L-31758-36A, L-31795-36A, L-31854-36A, RL-10566-36A, RL-30603-36A, RL-34831-36A, RL-34832-36A, RL-34875-36A, RL-34973-36A, RL-34996-36A.

**O-360-A3AD** - L-18055-36A.

**O-360-A4A** - L-2284-36A, L-3324-36A, L-11220-36A, L-14007-36A, L-14568-36A, L-15225-36A, L-18625-36A, L-12014-36A, L-14289-36A, L-17001-36A, L-18967-36A, L-19432-36A, L-24126-36A, L-17507-36A, L-27856-36A, L-32212-36A, RL-13650-36A, RL-19340-36A, RL-34856-36A, RL-34972-36A, RL-35021-36A.

**O-360-A4G** - L-4531-36A, L-14903-36A, L-17997-36A, RL-34688-36A, RL-34690-36A.

**O-360-A4J** - L-26903-36A.

**O-360-A4K** - L-21237-36A, L-24113-36A, L-24448-36A, L-24612-36A, L-24902-36A, L-26138-36A, L-28467-36A, RL-34997-36A.

**O-360-A4M** - L-989-36A, L-1182-36A, L-1441-36A, L-1871-36A, L-3453-36A, L-11022-36A, L-12104-36A, L-12658-36A, L-13317-36A, L-15223-36A, L-15979-36A, L-16316-36A, L-16710-36A, L-18506-36A, L-20531-36A, L-21504-36A, L-22008-36A, L-22293-36A, L-22772-36A, L-22896-36A, L-23368-36A, L-23886-36A, L-23891-36A, L-23996-36A, L-24728-36A, L-24917-36A, L-25726-36A, L-25774-36A, L-26648-36A, L-27005-36A, L-27025-36A, L-27262-36A, L-27347-36A, L-27963-36A, L-28568-36A, L-29461-36A, L-29924-36A, L-29956-36A, L-30223-36A, L-30887-36A, L-31733-36A, L-32274-36A, RL-1355-36A, RL-22430-36A, RL-25889-36A, RL-27797-36A, RL-28487-36A, RL-28768-36A, RL-29383-36A, RL-30149-36A, RL-34805-36A, RL-34806-36A, RL-34813-36A, RL-34814-36A, RL-34826-36A, RL-34827-36A, RL-34829-36A, RL-34830-36A, RL-34853-36A, RL-34878-36A, RL-34967-36A.

**O-360-A4N** - L-29006-36A, L-30323-36A.

**O-360-C1F** - L-31067-36A, RL-34941-36A.

**O-360-C1G** - L-27646-36A.

**O-360-C2E** - L-14674-36A, L-22298-36A, L-30592-36A.

**O-360-E1A6D** - L-133-77T, L-286-77T, L-355-77T, L-380-77T, L-421-77T, L-488-77T, RL-132-77T, RL-196-77T, RL-373-77T.

**O-360-F1A6** - L-14373-36A, L-17390-36A, L-19022-36A, L-20330-36A, L-20370-36A, L-22947-36A, L-23006-36A, L-27647-36A, L-28119-36A, L-32802-36A, RL-9393-36A, RL-10101-36A, RL-34857-36A, RL-34887-36A.

**IO-360-A1A** - L-1332-51A, L-4207-51A, L-12756-51A, L-13861-51A, L-14628-51A, L-14663-51A, L-17744-51A, L-18697-51A, L-18717-51A, L-19235-51A, L-19546-51A, L-21747-51A.

**IO-360-A1B** - L-9878-51A, RL-16682-51A.

**IO-360-A1B6** - L-13946-51A, L-17330-51A, L-18231-51A, L-19023-51A, L-20003-51A, L-20165-51A, RL-6833-51A, RL-9773-51A, RL-13004-51A, RL-19237-51A, RL-19483-51A.

**IO-360-A1B6D** - L-8912-51A, L-16560-51A, L-21731-51A, L-24770-51A.

**IO-360-A3B6D** - L-13530-51A, L-14358-51A, L-15567-51A, L-16284-51A, L-16366-51A, L-16500-51A, L-17653-51A, L-19394-51A, L-21854-51A, L-22788-51A, L-23111-51A, L-23277-51A, L-23984-51A, L-25427-51A, L-25565-51A, RL-15506-51A, RL-17176-51A.

**IO-360-B1B** - L-11385-51A, L-16833-51A, L-23793-51A.

**IO-360-B1E** - L-18729-51A, L-22091-51A, L-24818-51A.

**IO-360-B1F** - L-20814-51A.

**IO-360-C1C** - L-3040-51A, L-4385-51A, L-4387-51A, L-10383-51A, L-11554-51A, L-12280-51A, L-17139-51A, L-20674-51A, L-23841-51A, L-25269-51A, L-26336-51A.

**IO-360-C1C6** - L-6373-51A, L-6444-51A, L-10196-51A, L-13206-51A, L-13444-51A, L-14201-51A, L-15017-51A, L-18700-51A, L-20795-51A, L-20955-51A, L-21193-51A, L-22405-51A, L-22698-51A, L-23070-51A, L-24817-51A.

**IO-360-C1E6** - L-1009-51A, L-1606-51A, L-10605-51A, L-10804-51A, L-12406-51A, L-16636-51A.

**HIO-360-D1A** - L-1462-51A, L-7627-51A, L-8276-51A, L-8372-51A, L-8458-51A, L-8500-51A, L-12228-51A, L-14165-51A, L-20300-51A, L-22024-51A, L-23779-51A, L-24094-51A, L-24215-51A, L-24467-51A, L-24666-51A, L-24880-51A, L-25294-51A, L-25571-51A, L-25690-51A, L-26320-51A, RL-4915-51A, RL-5753-51A.

**HIO-360-E1AD** - RL-10100-51A.

**HIO-360-F1AD** - RL-16623-51A, RL-24133-51A.

**LIO-360-C1E6** - L-136-67A, L-339-67A, L-1001-67A.

**LO-360-A1G6D** - L-126-71A, L-279-71A, L-357-71A, L-361-71A, L-389-71A, L-505-71A, L-535-71A, L-562-71A, RL-416-71A, RL-567-71A, RL-570-71A.

**LO-360-E1A6D** - L-121-72T, L-196-72T, L-496-72T, L-530-72T, RL-204-72T, RL-312-72T.

**TO-360-C1A6D** - L-259-69A.

**TIO-360-C1A6D** - L-209-64A.



**ATTACHMENT I – Service Bulletin No. 527C**

**OVERHAULED AND REMANUFACTURED ENGINES (Continued):**

AEIO-360-A1A - RL-24578-51A.  
AEIO-360-A1D - RL-21010-51A.  
AEIO-360-B1F - RL-24501-51A.  
AEIO-360-B2F - L-24504-51A, L-24616-51A, L-24945-51A, RL-24577-51A.  
AEIO-360-H1A - L-20501-51A, L-24617-51A.  
O-540-A1A5 - L-23815-40, L-23888-40.  
O-540-A1D5 - L-4788-40, L-5729-40, L-10097-40, L-14318-40, L-24042-40.  
O-540-B1A5 - L-15598-40.  
O-540-B2C5 - L-2814-40, L-10005-40, L-16701-40, L-22882-40, RL-4813-40.  
O-540-B4B5 - L-23318-40A.  
O-540-E4A5 - RL-10840-40A.  
O-540-E4B5 - L-9204-40, L-1379-40, L-21981-40.  
O-540-E4C5 - L-14687-40A, L-15061-40, L-16383-40, L-18136-40A, L-19499-40A, L-20412-40A, L-21948-40A, L-22209-40A, L-22566-40A, L-22603-40A, L-23187-40A, L-23268-40, L-23871-40A, L-24119-40A, L-24353-40A, L-24433-40A, L-24466-40A, L-24679-40A, RL-8509-40, RL-12561-40A, RL-13037-40A, RL-16073-40, RL-17887-40A, RL-23442-40A, RL-23484-40A, RL-23567-40A, RL-24395-40A, RL-24396-40A, RL-24415-40A.  
O-540-F1B5 - L-24552-40A, L-24600-40A, L-24762-40A.  
O-540-G1A5 - L-15852-40, L-24118-40.  
IO-540-AA1A5 - L-19180-48A.  
IO-540-A1C5 - L-1425-40.  
IO-540-B4A5 - L-4289-48.  
IO-540-C4B5 - L-1936-48, L-2736-48, L-10322-48, L-18973-48, L-19315-48, L-19461-48, RL-19121-48.  
IO-540-C4B5 - L-14091-48A, L-16014-48A, L-16849-48A, L-18738-48A, L-19241-48A, L-20820-48A, L-20851-48A, L-21445-48A.  
IO-540-C4D5D - L-20470-48A, L-22388-48A, L-23644-48A.  
IO-540-D4A5 - L-2924-48, L-3113-48, L-3192-48, L-3243-48, L-4289-48.  
IO-540-E1A5 - L-17599-48, L-20126-48, L-20920-48, RL-1791-48.  
IO-540-E1B5 - L-1587-48, L-1817-48, L-2303-48, L-2380-48, L-2512-48, L-17598-48, L-18073-48.  
IO-540-K1A5 - L-13405-48A, L-17748-48A, L-18769-48, L-21767-48A, L-22185-48A.  
IO-540-K1A5D - L-13795-48A, RL-11387-48A.  
IO-540-K1B5 - L-17561-48, L-21267-48A, RL-14483-48A, RL-14542-48A.  
IO-540-K1G5 - L-4277-48A, L-5650-48A, L-13303-48A, L-14117-48A, L-15002-48A, L-16725-48A, L-16984-48A, L-17326-48A, L-17800-48A, L-25124-48A, L-25268-48A, L-24650-48A.  
IO-540-K1G5D - L-12241-48A, L-15344-48A, L-15517-48A, L-16484-48A, L-18614-48A, L-19470-48A, L-19646-48A, L-20723-48A, L-21901-48A, L-22393-48A.  
IO-540-N1A5 - L-7183-48A, L-17706-48A.  
IO-540-S1A5 - L-14251-48A, L-20516-48A, L-20864-48A, RL-10798-48A, RL-15862-48A.  
IO-540-T4B5 - L-25134-48A.  
IO-540-T4B5D - L-14265-48A, L-20393-48A, RL-15001-48A.  
TIO-540-A2B - L-511-61, L-1786-61.  
TIO-540-A2C - L-1320-61A, L-2138-61A, L-4479-61A, L-5069-61A, L-6323-61, L-6324-61, L-6937-61A, L-7095-61A, L-7342-61A, L-7651-61A, L-7676-61A, L-8129-61A, L-8737-61A, RL-2141-61, RL-6800-61A, RL-7875-61A, RL-7975-61A, RL-8213-61A, RL-8299-61A.  
TIO-540-AE2A - L-2560-61A, RL-7100-61A.  
TIO-540-AF1B - RL-7578-61A.  
TIO-540-C1A - RL-8918-61A.  
TIO-540-F2BD - L-6124-61A, L-6292-61A, L-6562-61A, L-7130-61A, RL-6619-61A, RL-7770-61A.  
TIO-540-J2B - L-699-61A, L-1679-61A, L-1943-61A, L-3102-61A, L-3470-61A, L-4242-61A, L-4338-61A, L-4676-61A, L-4912-61A, L-4985-61A, L-6423-61A, L-8611-61A, RL-4185-61A, RL-6555-61A, RL-8045-61A, RL-8338-61A, RL-8762-61A, RL-9522-61A.  
TIO-540-J2BD - L-108-61A, L-1234-61A, L-2368-61A, L-2649-61A, L-3260-61A, L-3423-61A, L-4019-61A, L-4217-61A, L-4433-61A, L-4551-61A, L-4552-61A, L-4614-61A, L-4710-61A, L-4732-61A, L-4835-61A, L-4875-51A, L-5429-61A, L-6124-61A, L-6291-61A, L-6303-61A, L-6618-61A, L-6624-61A, L-6892-61A, L-7085-61A, L-7122-61A, L-7198-61A, L-7302-61A, L-7307-61A, L-7549-61A, L-7557-61A, L-7590-61A, L-7815-61A, L-8253-61A, L-8323-61A, L-8328-61A, L-8508-61A, L-8850-61A, L-8851-61A, L-9083-61A, RL-2841-61A, RL-4031-61A, RL-5183-61A, RL-5300-61A, RL-7099-61A, RL-7669-61A, RL-7763-61A, RL-8938-61A, RL-8999-61A.  
TIO-540-S1AD - L-1839-61A, L-3023-61A, L-3673-61A, L-4446-61A, L-5187-61A, L-5444-61A, L-7112-61A, L-7174-61A, L-7176-61A, L-8161-61A, RL-4452-61A.

**OVERHAULED AND REMANUFACTURED ENGINES (Continued):**

**TIO-540-V2AD** - L-8482-61A, L-8522-61A.

**LTIO-540-F2BD** - L-154-68A, L-1290-68A, L-2365-68A, L-2806-61A, RL-2039-68A, RL-2547-68A.

**LTIO-540-J2B** - L-588-68A, L-1484-68A, L-1485-68A, L-1971-68A, L-2306-68A, L-2708-68A, RL-2722-68A.

**LTIO-540-J2BD** - L-345-68A, L-422-68A, L-1069-68A, L-1087-68A, L-1115-68A, L-1179-68A, L-1507-68A, L-1720-68A, L-1796-68A, L-1844-68A, L-1853-68A, L-1885-68A, L-2054-68A, L-2181-68A, L-2222-68A, L-2281-68A, L-2311-68A, L-2320-68A, L-2406-61A, L-2484-68A, L-2680-68A, L-2730-68A, L-2743-68A, L-2883-68A, RL-211-68A, RL-1118-68A, RL-1459-68A, RL-1594-68A, RL-1681-68A, RL-1743-68A, RL-2132-68A, RL-2232-68A, RL-2277-68A, RL-2326-68A, RL-2482-68A, RL-2483-68A, RL-2510-68A, RL-2582-68A, RL-2590-68A, RL-2667-68A, RL-2670-68A, RL-2706-68A, RL-2839-68A, RL-2880-68A.

**LTIO-540-V2AD** - L-2750-68A, L-2754-68A, L-2775-68A.

**AEIO-540-D4B5** - RL-23717-48A.

**AEIO-540-L1B5** - L-23715-48A, L-24834-48A, L-25212-48A.

**VO-540-C2A** - L-2304-43.

**TIO-541-E1A4** - L-219-59C, L-1749-59C.

**TIO-541-E1C4** - L-153-59, L-655-59, L-1756-59, RL-292-59, RL-1744-59, RL-1746-59, RL-1772-59, RL-1774-59.

**TIGO-541-E1A** - L-131-62, L-440-62, L-461-62, L-702-62, RL-195-62.

**IO-720-A1B** - L-562-54A, L-597-54A, RL-1284-54A.

**IO-720-D1CD** - L-881-54A.

**TEXTRON SERVICE CENTER:**

**Conversions:**

**TIO-540-AF1B** - L-9120-61A, L-9356-61A, L-9459-61A, L-9852-61A.

**Repairs:**

**O-320-B2C** - L-49834-27AC.

**IO-540-S1A5** - L-18211-48A.

**TIO-540-AE2A** - L-9590-61A.

**TIGO-541** - RL-699-62.

**ATTACHMENT II - Service Bulletin No. 527C**

**Cylinder Kits containing P/N LW-14077 Piston Pin shipped during the time period December 15, 1995 thru September 17, 1996 are as follows:**

05K21100  
05K21101  
05K21102  
05K21103  
05K21104  
05K21108  
05K21109  
05K21110  
05K21112  
05K21116  
05K21118  
05K21119  
05K21120  
05K21121  
05K21122  
05K21124  
05K21192  
05K21204  
05K21223  
05K21226  
05K21228  
05K21234  
05K21241  
05K21242  
05K21260  
05K21262  
05K21264  
05K21265  
05K21269  
05K21270  
05K21272  
05K21273  
05K21274  
05K21276  
05K21278  
05K21745  
05K22128  
05K22129  
05K22177