

TEXTRON Lycoming

652 Oliver Street
Williamsport, PA 17701 U.S.A.
717/323-6181

MANDATORY SERVICE BULLETIN

DATE: October 7, 1996

Service Bulletin No. 525A
(Supersedes Service Bulletin No. 525)
Engineering Aspects are
FAA Approved

SUBJECT: Inspection of High Pressure Fuel Pump P/N LW-15473

MODELS AFFECTED: New, remanufactured and overhauled engines from Textron Lycoming with P/N LW-15473 fuel pumps shipped between July 18, 1995 and August 14, 1996 inclusive. Engine models included are (L) IO-320, -360, -540; AEIO-320, -360, -540; HIO-360, TO-360 and O-540-L.

Fuel pumps P/N LW-15473 purchased through distribution between July 18, 1995 and August 14, 1996 inclusive.

TIME OF COMPLIANCE: Before further flight of the aircraft.

Textron Lycoming has determined that a number of high pressure fuel pumps, P/N LW-15473, manufactured between June and October of 1995 may have manufacturing defects that may result in engine stoppage. Several instances have occurred where the retaining washer gasket has separated from the pull rod assembly and lodged in the pump outlet valve restricting fuel flow.

If your Textron Lycoming engine has a P/N LW-15473 high pressure fuel pump installed, with flange number (manufacturer's code) scribed on the pump of 154739506, 154739507 or 154739510, it must be inspected before further flight of your aircraft.

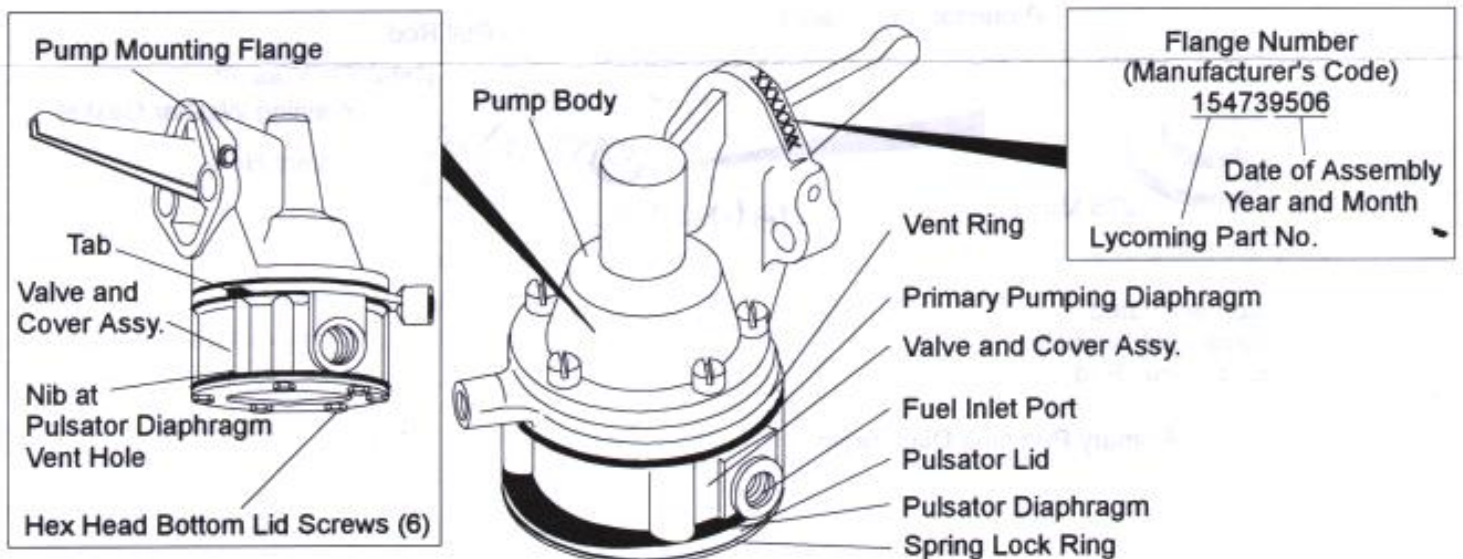

Figure 1.

FUEL PUMP INSPECTION PROCEDURE

1. Remove the fuel pump from the engine.

CAUTION: ONLY DISASSEMBLE PUMP AS INDICATED.

2. With a red permanent ink felt tip marker, make an alignment mark down the side of the pump assembly at the vent passage boss (Refer to Figure 4) to aid in part alignment for subsequent reassembly. Ensure all parts (including diaphragm) are marked for reassembly.

3. Completely loosen but do not remove the six hex head bottom lid screws and remove the entire bottom section of the pump as a unit assembly including the lid screws and valve and cover assembly. (Refer to Figure 1 and 4.) Set this unit assembly aside for later examination (step 7). Note, this unit may be further disassembled for cleaning.

4. Visually inspect for proper location and retention of the retaining washer gasket in the pull rod/diaphragm assembly. (Refer to Figure 2.) If the gasket is not found between the retaining washer and diaphragm protector or it protrudes more than 1/16 inch beyond the retaining washer at any point, the pump is unserviceable and must be replaced.

5. Using vernier or dial calipers, measure the diameter of the larger copper plated expanded end of the pull rod immediately next to the retaining washer (see Figure 2). If this diameter measures less than .275 inches, the pump is unserviceable and must be replaced.

6. Visually inspect the exposed portion of the primary pumping diaphragm for cracks, perforations, tears, and/or separations. If the diaphragm is cracked, perforated, torn or separated, the pump is unserviceable and must be replaced.

7. Examine the pulsator diaphragm from the unit assembly set aside in step 3, (Refer to Figure 4) as follows:

a. Remove the valve and cover assembly from the six hex head retaining screws.

b. Carefully remove the pulsator diaphragm from the pulsator lid. Examine the pulsator diaphragm for cracks, perforations, tears and/or separations of the rubber elastomer from the fabric reinforcement, particularly at the clamped periphery of the diaphragm. A diaphragm showing cracks, perforations, tears or separations should be replaced. The replacement diaphragm, P/N 6414698, can be obtained by contacting a Textron Lycoming distributor. It is recommended that the diaphragm be replaced.

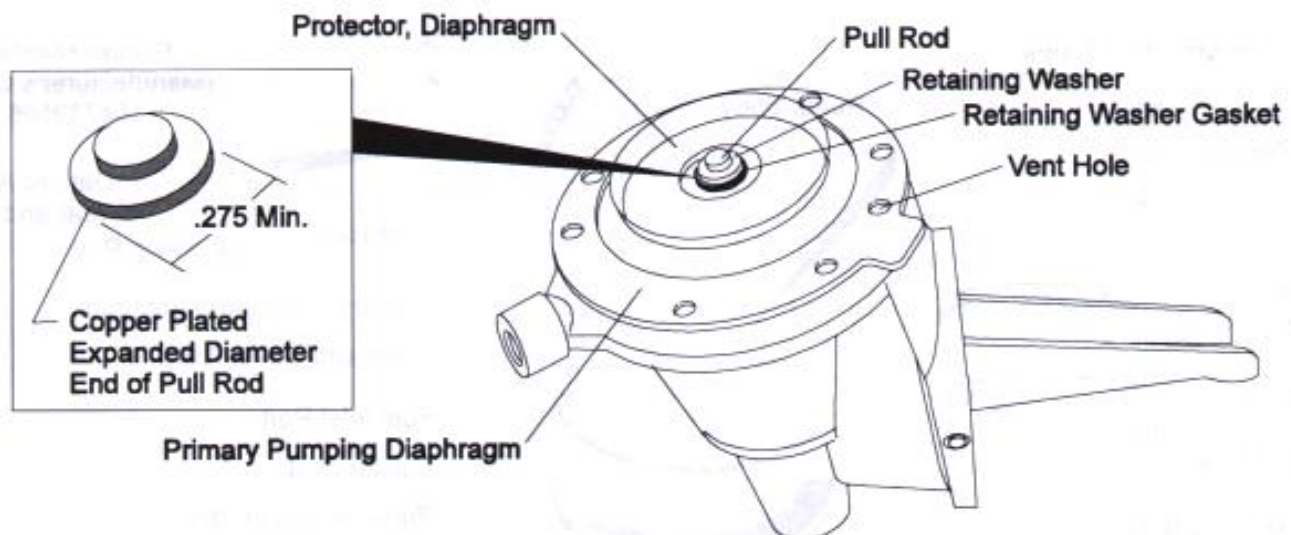

Figure 2.

REASSEMBLY PROCEDURE

NOTE: Be sure all parts are thoroughly clean prior to reassembly of the fuel pump.

8. Place the pulsator diaphragm over the pulsator lid, aligning the pulsator diaphragm vent hole (small hole near the diaphragm periphery) with the vent hole in pulsator lid. (Refer to Figure 3.)

CAUTION

INSTALL PULSATOR DIAPHRAGM SO THAT THE SAME SIDES (ORIGINAL INSTALLATION DEPRESSIONS) ARE ALIGNED WITH THE DIVIDER IN THE PULSATOR LID.

9. Place the valve and cover assembly on the diaphragm, aligning its vent passage with the pulsator diaphragm and pulsator lid vent holes. (Refer to Figure 3.)

10. Using the alignment mark made in step 2 as a guide, reassemble the "unit assembly" to the pump body observing the correct orientation of the fuel ports. The valve and cover assembly vent passage must align with the tab on the primary pumping diaphragm. (Refer to Figure 4.) Looking at the pump from the rear as installed on the engine, the fuel inlet port is on the right. Torque the six hex head bottom lid screws alternately and evenly until a torque value of 30 inch pounds is obtained.

CAUTION

IF THE SPRING LOCK RING IS NOT FLAT AFTER TORQUING, THE RING IS INSTALLED UPSIDE DOWN.

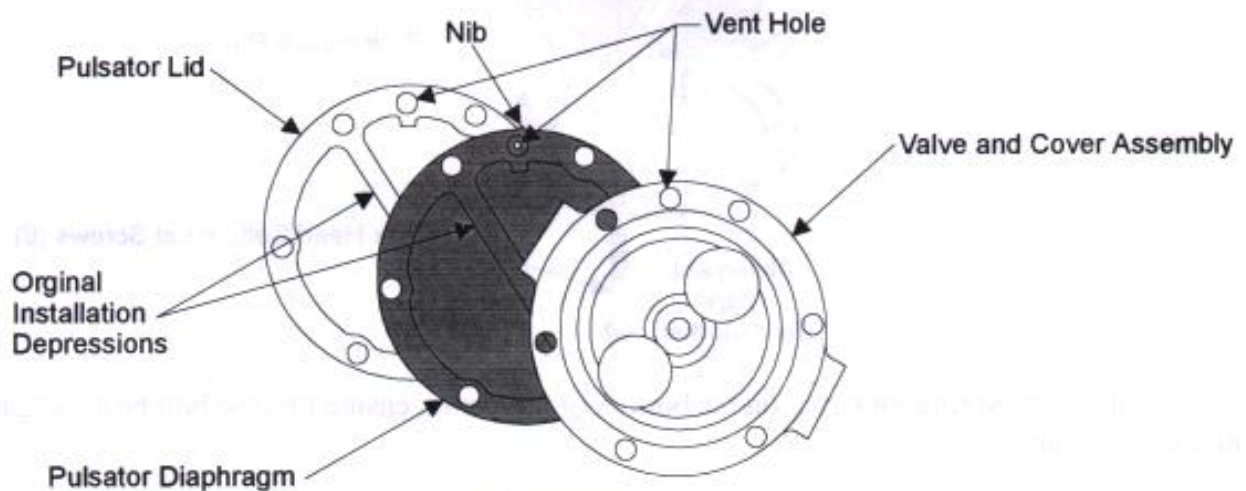

Figure 3.

COMPLIANCE IDENTIFICATION AND REINSTALLATION

11. To identify that this examination was accomplished on the pump assembly, mark an "A" by metal stamp or scribe on the pump mounting flange immediately before the flange number (manufacturer's code). (Refer to Figure 1). If necessary due to space constraints, the "A" may be located just above the rocker shaft pin. An entry in the engine and/or aircraft log book should also be made.

12. If the pump was removed for examination, reinstall it per standard practice according to the appropriate Manual. Examine the port fitting "o" rings (P/N MS29512-06) and the mounting flange gasket (P/N 60096), replace if necessary.

Once the pump is reinstalled on the engine, run the engine (to rated RPM) on the ground and inspect the pump and fuel lines for leaks.

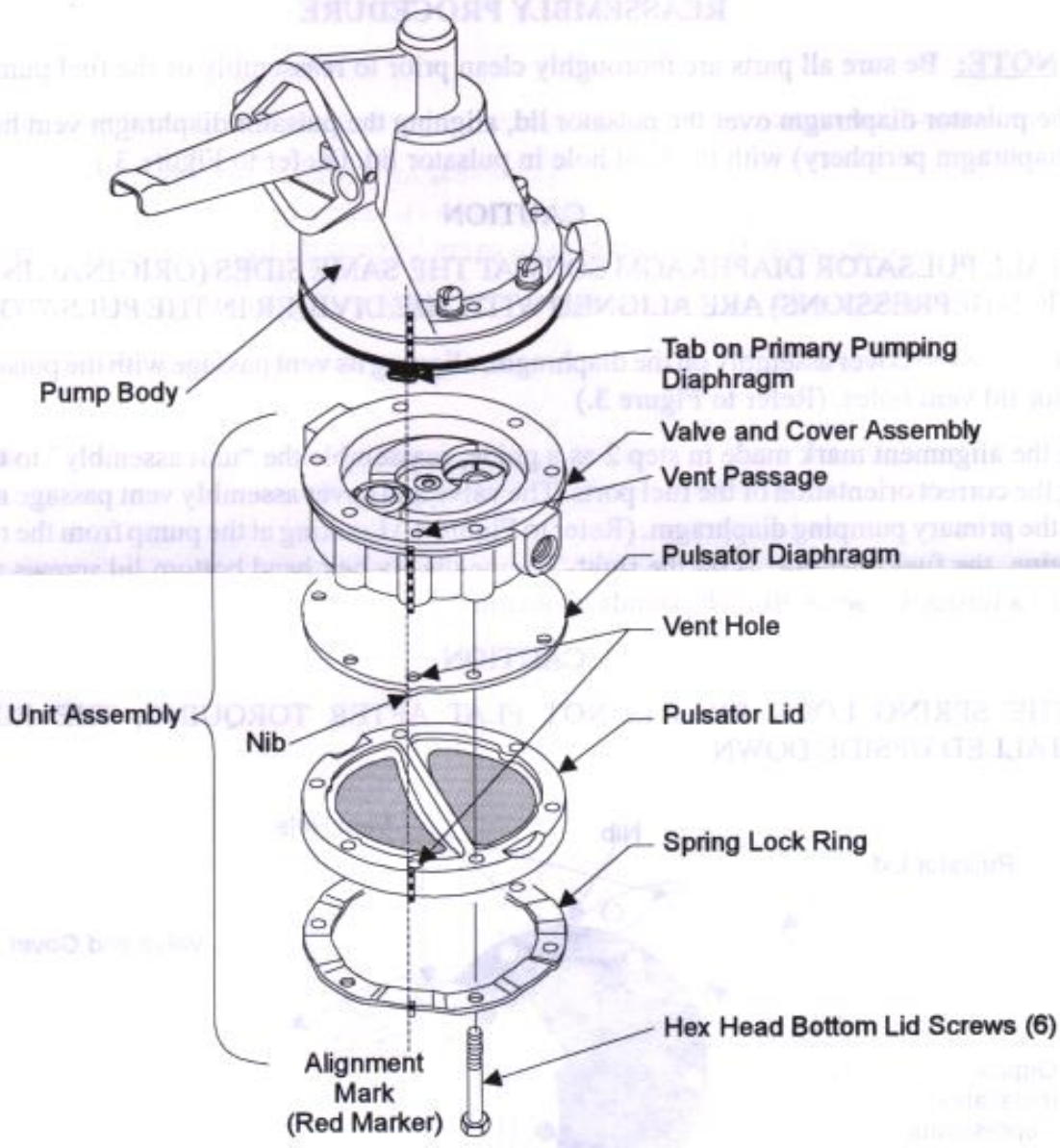

When reinstalling the spring lock ring on the bottom of the pump, ensure that the bolt head is against the high segments of the ring.

CAUTION

IF THE SPRING LOCK RING IS NOT FLAT AFTER TORQUING, THE RING IS INSTALLED UPSIDE DOWN.

Figure 4.

WARRANTY:

LABOR: A labor allowance of 1/2 hour will be provided to inspect and identify the fuel pump flange number (manufacturer's code) including removal and replacement of the cowling. An additional 2 hour labor allowance will be provided for inspection and/or replacement of the affected fuel pumps.

MATERIAL: If required by inspection, one (1) replacement pulsator diaphragm, P/N 6414698, or one (1) each replacement fuel pump, P/N LW-15473, through a Textron Lycoming Distributor. Unserviceable pumps must be returned to Textron Lycoming in accordance with the warranty procedure.

This warranty allowance will be in effect for one year from the date of this Service Bulletin.